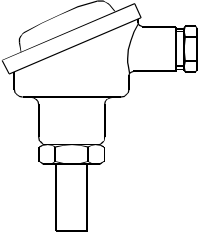
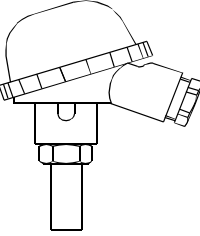
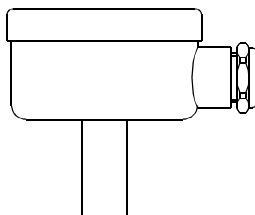
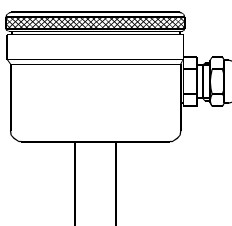

RTD TEMPERATURE SENSOR, TYPE SPT

TYPE SPT100-X-xx, with class B (1/3-DIN) Pt100 element

STANDARD MODEL

TERMINAL HEAD : see below RTD elements : 3-wire Pt100, LX: single thinfilm layer element : 6-wire 2xPt100, LD: duplex thinfilm layer element : 3-wire Pt100, HX: single ceramic element : 6-wire 2xPt100, HD: duplex ceramic element PROBE : standard upto 100 mm, AISI321/1.4541, see page 4	CONNECTIONS : AISI304/1.4301, see page 5 and 6 RANGE : LX and LD type = -50/+200°C : HX and HD type = -200/+400°C TOLERANCE : class B acc. to IEC751, 1/3-DIN CABLE GLAND : type A, B, S and K; PG-11 OPTIONS : built-in transmitters: see page 6
---	---

TYPE	MODEL	<i>xx = RTD Element:</i>			
		LX -50/+200°C	LD -50/+200°C DUPLEX	HX -200/+400°C	HD -200/+400°C DUPLEX
C with 2000 mm extension cable IP-65 PER 1000 MM CABLE EXTRA:		SPT100-C-LX	SPT100-C-LD	SPT100-C-HX	SPT100-C-HD
A aluminium DIN 43729 form B IP-68	 PG 16	SPT100-A-LX	SPT100-A-LD	SPT100-A-HX	SPT100-A-HD
B polyamide BBK IP-55	 PG 16	SPT100-B-LX	SPT100-B-LD	SPT100-B-HX	SPT100-B-HD
S AISI304/1.4301 bayonet-lock IP-65	 PG 11	SPT100-S-LX	SPT100-S-LD	SPT100-S-HX	SPT100-S-HD
K AISI304/1.4301 screwed cover IP-68	 PG 9	SPT100-K-LX	SPT100-K-LD	SPT100-K-HX	SPT100-K-HD

PROBE LENGTH AND DIAMETER FOR TYPE SPT100

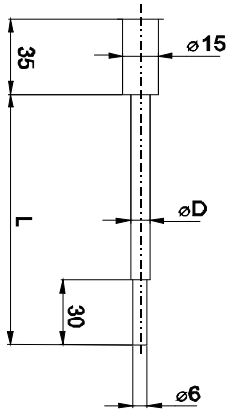
TYPE	MODEL	L x ØD (mm)	EXTRA COSTS	"L" AISI321/1.4541 >100mm*	EXTRA COSTS
A PLAIN STEM	 <p style="text-align: center; font-size: small;">L = standard upto 100 mm</p>	6, 8 or 9 without tip	--	per 50 mm	
		8 or 9 with tip Ø6		per 50 mm	
		10 or 12 with tip Ø6		per 50 mm	

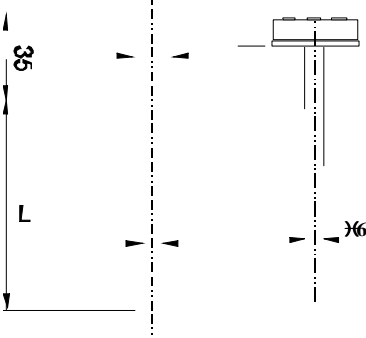
TYPE	MODEL	L x ØD (mm)	EXTRA COSTS	"L" AISI321/1.4541 >100mm*	EXTRA COSTS
E INSERT TYPE: PROBE WITH EXCHANGEABLE ELEMENT	 <p style="text-align: center; font-size: small;">L = standard upto 100 mm</p>	9 without tip		per 50 mm	
		10 or 12 with tip Ø9		per 50 mm	

OPTIONS for probes		EXTRA COSTS (per 100 mm)
POLISHED PROBE (MECHANICAL)	FOR ALL DIAMETERS	
PROBE AISI316/1.4401	FOR PROBE DIAMETERS Ø 6, 8, 9, 10 and 12mm	

THREADED CONNECTIONS FOR SPT100

TYPE	MODEL	EXTRA COSTS			
		CONNECTION	SW 1	SW 2	AISI304/1.4301
B COUPLING NUT <i>(standard model)</i>		1/2" BSP	27	--	
		3/4" BSP	32	--	
		1" BSP	41	--	
BL COUPLING NUT <i>(long model)</i>		1/2" BSP	27	--	
		3/4" BSP	32	--	
		1" BSP	41	--	
C FIXED NIPPLE <i>(standard model)</i>		1/2" BSP/NPT	27	--	
		3/4" BSP/NPT	32	--	
		1" BSP/NPT	41	--	
CL FIXED NIPPLE <i>(long model)</i>		1/2" BSP/NPT	27	--	
		3/4" BSP/NPT	32	--	
		1" BSP/NPT	41	--	
A 04 TURNING NIPPLE <i>(standard model)</i>		1/2" BSP	27	--	
		3/4" BSP	32	--	
		1" BSP	41	--	
AL 04 TURNING NIPPLE <i>(long model)</i>		1/2" BSP	27	--	
		3/4" BSP	32	--	
		1" BSP	41	--	
CS 3 ADJUSTABLE SLIDING CONNECTION	<p>FOR FEMALE CONNECTION: SEE PAGE 6</p>	1/2" BSP/NPT	22	27	
		3/4" BSP/NPT	22	32	
		1" BSP/NPT	22	36	

OPTIONS FOR THREADED CONNECTIONS

OPTIONS		EXTRA COSTS
1/2" BSP female	FOR CONNECTION TYPE CS3	
3/4" BSP female		
1" BSP female		
M24x1.5	add basic price connection 3/4" bsp with:	
M20x1.5	add basic price connection 3/4" bsp with:	
M18x1.5	add basic price connection 1/2" bsp with:	
3/8" BSP	add basic price connection 1/2" bsp with:	
1/4" BSP	add basic price connection 1/2" bsp with:	

SANITARY CONNECTIONS FOR SPT100

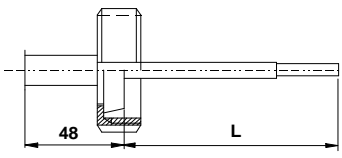
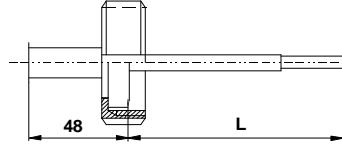
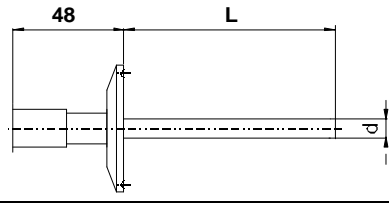
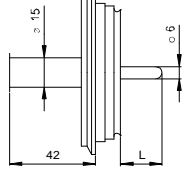
TYPE	MODEL WITH POLISHED BULB	CONNECTION	EXTRA COSTS
			AISI316/1.4401
CM-DIN <i>sanitary coupling acc. to DIN 11851</i>		1" - NW25	
		1½" - NW40	
		2" - NW50	
		3" - NW75	
CM-SMS <i>sanitary coupling acc. to SMS 1145</i>		1" - NW25	
		1" - NW40	
		2" - NW50	
TC <i>sanitary connection acc. to ISO 2852</i>		1" - NW25	
		1" - NW40	
		2" - NW50	
TV <i>sanitary VARIVENT In-Line connection</i>		DN50 For In Line housing DN25	
		DN68 For In Line housing DN40 and up	

BUILT-IN RTD TRANSMITTER

TRANSMITTER TYPE		EXTRA COSTS
TRP	4-20mA, 2-wire, +13..+35Vdc	
TRPex	4-20mA, 2-wire, +13..+35Vdc, Eex-ia-IIC-T4..T6	O.D.